



MAKE POSSIBLE WITH ESAB.

13-16 January 2025

STEEL FAB WELDING COMPETITION 2025

INTRODUCTION

As a leading name in the welding industry, ESAB is thrilled to sponsor the SteelFab competition, bringing together passionate welders to showcase their skills and expertise.

Let the welding torches ignite the spirit of the competition!

ABOUT THE COMPETITION

Welding process: SMAW (Shielded metal arc welding)

Welding position: 5G

Coupons: Each participant will prepare the required coupons as follows:

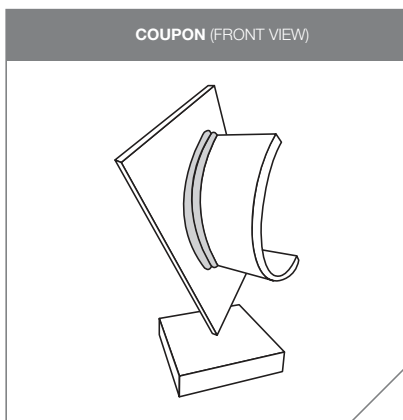

Coupon's material: Carbon Steel ASTM A 36 thickness 6 mm

Electrode: ESAB OK 53.68 (E7016-1 H4 R) Root + OK 55.00 L (E7018-1 H4 R) Filling & capping

EVALUATION CRITERIA

There are three main assessing criteria to evaluate the participants in the competition:

1. The Visual appeal of the weld
2. Respecting the WPS parameters
3. An optimal Completion time around one hour
(This criterion will be used to finalize the decision in case where the first 2 criteria are met equally)



MAKE POSSIBLE WITH ESAB.

13-16 January 2025

STEEL FAB WELDING COMPETITION 2025

RULES OF SAFETY

All participants in the competition should adhere to the following rules of safety:

While welding or grinding, all welders should wear the appropriate PPEs:

1. Welding gloves
2. Welding helmet
3. Body protective clothing: welding jacket and trousers OR welding apron hand sleeves
4. Safety shoes

All welders should follow the instructions below:

1. Wear eye goggles with side shields while removing slag or while standing next to the welding stations.
2. Never look directly at the arc without a welding helmet or shaded eye goggles.
3. Do NOT touch the hot weld without wearing welding gloves.
4. Do NOT work right next to the welding power source.
5. Do NOT wrap any cables around your body.
6. Do NOT touch any live electrical part.

AWARDS & RECOGNITION

There will be one winner, a 1st runner – up, and a 2nd runner – up.

The final round winner will get an Institutional Certificate from MEITI and will be highlighted on the SteelFab website & PR as the best welder at SteelFab 2024.

In addition to the latest welding equipment from ESAB, **ROGUE ES 200i PRO**.

The 1st runner – up, will get the **ESAB HandyArc 3.25i** power source, and the the 2nd runner – up, will win ESAB's welding helmet **SAVAGE A40**.